

NO.	COUNT	REVISIONS	DATE (Y/M/D)	APPROVED
△	-	-	-- / -- / --	-
△	-	-	-- / -- / --	-

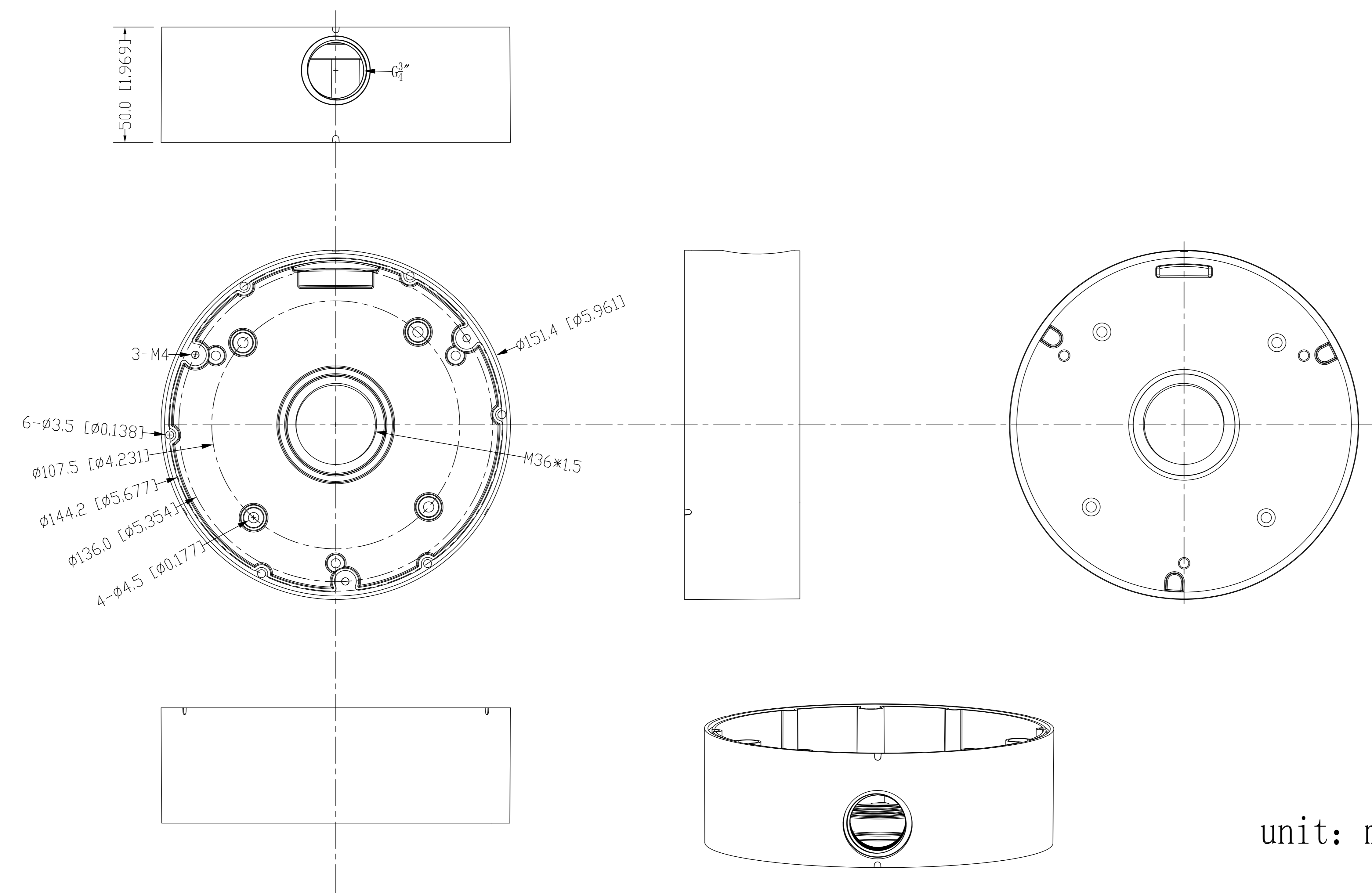

unit: mm[inch]

NO.	PART NO.	PART NAME	SIZE	SCALE	QTY	MATERIAL	REMARK
UNLESS OTHERWISE SPECIFIED, DIMENSIONS ARE IN MILLIMETERS AND TOLERANCES ARE AS FOLLOWS:							
0 - 3	± 0.1						
3 - 10	± 0.15						
10 - 30	± 0.2						
30 - 100	± 0.3						
100 - 300	± 0.5						
300 - 1000	± 1.0						
ANGULAR TOLERANCE: 30'							
DESIGNED							
CHECKED							
APPROVED							